

FEATURES

- High Efficiency
- Compact package
- Power indication LED
- Universal Input Power
- Dual +/-24V Output Power
- Active Power Factor Correction
- Short-circuit, overload, and over-voltage protection



GENERAL DESCRIPTION

The UP150D is an open-frame, dual-output, switch-mode power supply that Pangolin has had custom made for use along with our *Mach-DSP* servo driver. This power supply features high efficiency, active power factor correction and built in short-circuit, overload, and over-voltage protection. A green LED indicates that +/-24V power is present.

Thanks to its compact package size, the UP150D can be located close to the Mach-DSP servo driver inside a scan head or laser projector. And thanks to its high efficiency, it can be operated at continuous power levels up to 120W with no cooling, or greater than 150W with modest 20CFM fan cooling. Short-term operation up to 180W during very demanding portions of a scan pattern is also possible.

Although it is somewhat counter-intuitive, power supplies are specified in terms of “average current” (related to the power being delivered) while scanners are specified in terms of “RMS current” (related to the heating of the scanner coil). Because of this, it is not a simple matter to gage power supply requirements by referring to the RMS current specification found on a scanner’s datasheet. Average current supplied by the power supply will always be lower than RMS current driven into the scanner. Moreover, if a scanner is consuming 2 amps of current, half of this current is supplied by the positive supply rail and the other half is supplied by the negative supply rail (i.e. 1 amp from each supply rail). This is why, for most applications, the UP150D should be adequate for use with any of our scanners, including the ScannerMAX Saturn 9 with 10mm mirrors.

The UP150D is very compact, inexpensive, and powerful. It has a collection of features that make it very convenient. However, since it’s a switch-mode power supply, it may not be the best choice for noise-sensitive applications that need to do further processing on signals that are output from the Mach-DSP. Those applications may be better served by fully analog power supplies.

OUTLINE DRAWING

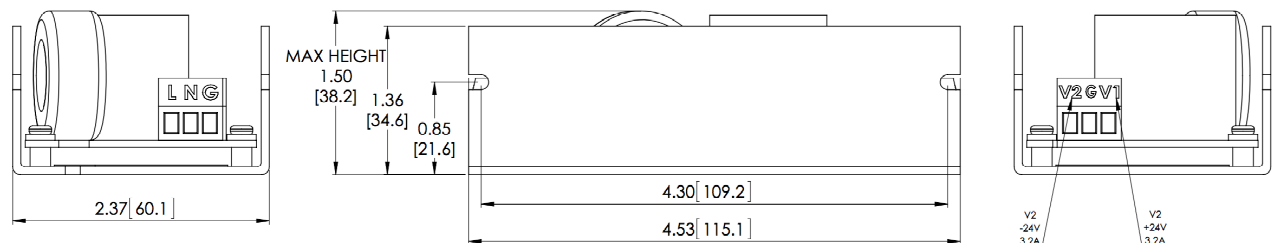

SPECIFICATIONS

| Parameter | Value | Units and Comments |
|-----------------------|-------------------|--|
| Input Voltage | 90 to 264 | Volts, AC |
| Input Current | 1.6 | Amps maximum, at 115 VAC (half that at 230VAC) |
| Power Factor | >= 0.95 | Active power factor correction |
| Input Frequency | 47 to 63 | Hertz |
| Output DC Voltage | +/- 24 | VDC (dual supply) |
| Output Rated Current | 0 to 3.2 | Amps, simultaneously from both outputs |
| Output Rated Power | 153.6 | Watts, with 20CFM fan cooling |
| Efficiency | 87 | Percent, at 230 VAC |
| Overload Protection | 105 to 150 | Percent, with auto-reset and recover |
| Operating Temperature | -10C to +50C | with 10% to 90% RH, non-condensing |
| Storage Temperature | -20C to +85C | with 10% to 90% RH |
| Size (inches) | 4.53 x 2.37 x 1.5 | W x L x H, Inches |
| Size (millimeters) | 115 x 60 x 38 | W x L x H, mm |
| Mass | 320 | Grams |

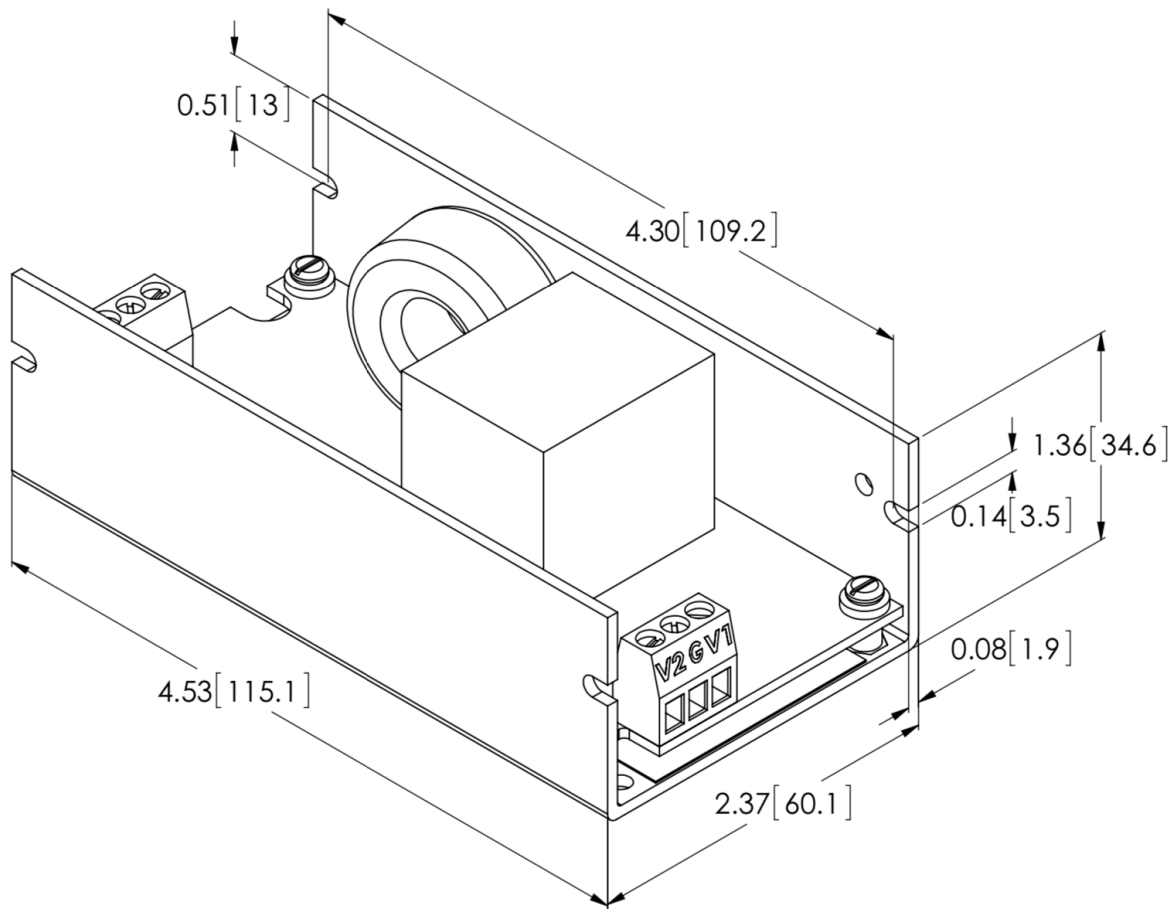

UP150D Connector Locations and Pinouts

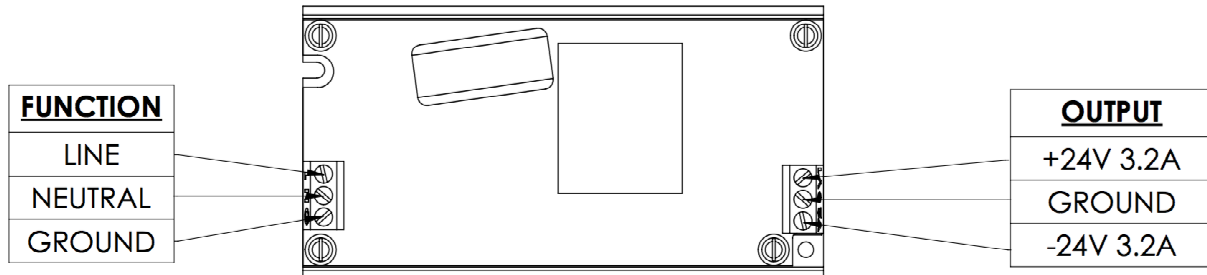

UP150D Mounting Holes

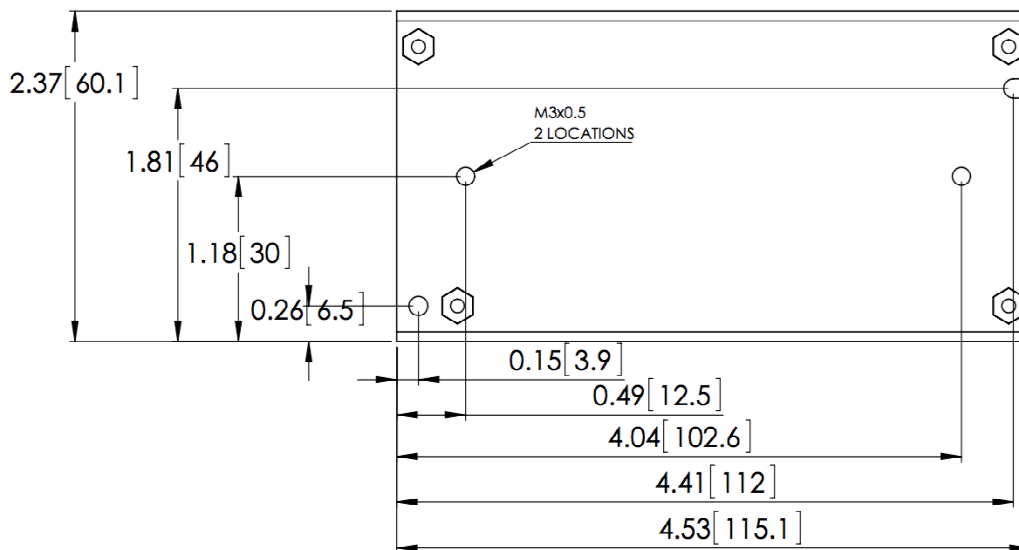



UP150D +/-24V Power Supply for ScannerMAX Mach-DSP

MORE INFORMATION

More information about ScannerMAX scanners and servo drivers, including additional application hints and tips can be found at www.ScannerMAX.com.

LASER SCANNING BOOK AVAILABLE

Detailed information about galvanometer scanners, servo driver techniques, and scanner applications can be found in the #1 best-selling book *LASER SCANNERS: Technologies and Applications*, written by Pangolin's President William R. Benner, Jr. The book can be found at www.LaserScanningBook.com.

PATENT AND TRADEMARK INFORMATION

ScannerMAX products are covered by one or more of the following patents:

US Utility Patent Number: 7,092,135
US Utility Patent Number: 7,688,432
US Utility Patent Number: 7,940,380
US Utility Patent Number: 8,254,045
US Utility Patent Number: 8,508,726
US Utility Patent Number: 8,963,396
US Utility Patent Number: 9,077,219
US Utility Patent Number: 9,195,061
US Utility Patent Number: 9,244,273
US Utility Patent Number: 9,270,144
US Utility Patent Number: 9,366,860
US Utility Patent Number: 9,530,559
US Utility Patent Number: 9,991,773
US Utility Patent Number: 10,284,038
US Utility Patent Number: 10,305,358
US Utility Patent Number: 10,539,433
US Utility Patent Number: 10,720,824
US Utility Patent Number: 10,734,857
US Utility Patent Number: 10,955,266
US Utility Patent Number: 11,162,819
US Utility Patent Number: 11,728,698
US Utility Patent Number: 11,735,969
German Patent (Utility Model) Number: 20 2012 009 275.8
German Patent (Utility Model) Number: 20 2013 000 369.3
German Patent (Utility Model) Number: 20 2013 003 263.4
German Patent (Utility Model) Number: 20 2014 000 846.9
German Patent (Utility Model) Number: 20 2014 002 094.9
German Patent (Utility Model) Number: 20 2016 000 737.9
German Patent (Utility Model) Number: 20 2019 002 282.1
German Patent (Utility Model) Number: 20 2020 000 007
German Patent (Utility Model) Number: 20 2020 000 420
Chinese Patent No. ZL201110066043.6
Chinese Patent No. ZL201210363949.9
Chinese Patent No. ZL201210363955.4
Chinese Patent No. ZL201310151544.3
Chinese Patent No. ZL201920775937.4
Chinese Patent No. ZL201310128586.5
Chinese Utility Model No. ZL201420101575.8
Chinese Utility Model No. ZL201420102156.6
Chinese Utility Model No. ZL201620112019.X
Other US and International Patents Pending.

Mach-DSP and *ScannerMAX* are trademarks of Pangolin Laser Systems, Inc.

U.S. Headquarters:

Pangolin Laser Systems, Inc.
1265 Upsala Road, Suite 1165
Sanford, FL 32711 – USA
Phone: +1-407-299-2088

Central Europe Branch Office:

Pangolin d.o.o.
Podutiška cesta 75
1000 Ljubljana, SLOVENIA
Phone: +386-1-517-4270